

INSTRUCTION MANUAL

CineKinetics 870

Projector Mechanism

Type 23-60071

Rev. January 1999



STRONG INTERNATIONAL

a division of Ballantyne of Omaha, Inc.

4350 McKinley Street

Omaha, Nebraska 68112 USA

Tel 402/453-4444 • Fax 402/453-7238

C O N T E N T S

PREFACE	1
INSTALLATION	2
THREADING	3
INITIAL OPERATION	4
MAINTENANCE	5
ADJUSTMENTS & REPLACEMENTS	
Lubrication	6
Shutter Timing	6
Replacement of Sprocket Shoes	7
Replacement of Feed Sprocket	8
Replacement of Intermittent Sprocket	8
Replacement of Timing Belts	9
Synchronization of Intermittent Movements	11
Replacement of Intermittent Movement	12
Replacement of Film Gate Components	13

PARTS LISTS

FIGURE 1, Main Frame	14
FIGURE 2, Cabinet	15
FIGURE 3, Film Compartment	16
FIGURE 4, Drive Side	19
FIGURE 5, Shutter Gearbox	24
FIGURE 6, Horizontal Sprocket Shaft	26
FIGURE 7, Film Gate	27
FIGURE 8, Sprocket Detent Assemblies	29
FIGURE 9, Intermittent Movement	31

PREFACE

THE *CINEKINETICS 870* is a large-format motion picture projector manufactured for Special Venue applications by Ballantyne of Omaha, Inc. Picture stability of the eight-perforation, 70mm frame is greatly enhanced by means of two intermittent movements; one above the picture aperture, and one below. This unique approach requires no film tension applied at the film gate, thus prolonging print life and reducing transport noise.

CONSTRUCTION of the rugged intermittent movements features a sturdy webbed starwheel and an oversize camshaft. All moving parts are immersed in an oil bath. Primary drive, applied to the lower intermittent movement, must apply 1440 rpm at the intermittent flywheel to achieve the 24 frame-per-second projection rate. Synchronization of the two movements is assured by means of timing belts. The brushless AC servomotor requires use of a motor speed controller.

A TWO-BLADED SHUTTER provides light cut-off directly behind the picture aperture to maximize lamphouse efficiency. The shutter drive gear train runs in an oil bath for constant lubrication..

THE LENS BARREL is securely anchored to the main frame, and features a fine vertical adjustment in addition to horizontal (focus) control. The barrel accommodates four-inch diameter lenses, and a reducer is available for use with 72mm diameter lenses.

A LIGHTED, ROOMY FILM COMPARTMENT simplifies the threading operation. Film-bearing parts subject to periodic replacement are mounted to subassemblies which are easily removed from the projector main frame. A replaceable aperture plate slides into the heat shield bracket behind the film gate.

PROVISION for two (installer-supplied) shaft encoders is made inside the drive compartment of the projector. The top and bottom sprockets of the threading path are film-driven to supply encoder input.

INSTALLATION

THE PROJECTOR MECHANISM is shipped in a sturdy wooden crate to prevent damage. It is secured to the crate using (2) 3/8-16 screws into the bottom plate, and a slotted 2x4 at the top of the crate restrains the eyebolt. Open the top of the crate, remove the 2x4 and the (2) screws, and hoist the projector from the crate using the eyebolt.

FOUR HOLES, tapped 3/8-16, are located on the back plate, and drilled in the standard pattern to permit mounting the CineKinetics projector to a conventional projection pedestal. After mounting the projector to the pedestal, the eyebolt may be removed.

NO VOLTAGE is applied directly to the drive motor. See the motor controller manual furnished separately for instructions regarding installation and operation.

A STEPDOWN TRANSFORMER (Part No. 81-64006) is furnished to supply 12 V.AC to the framing light. Wiring instructions are on the transformer; connect 120 V.AC to transformer terminals 1 & 4, and install jumpers between terminals 1 & 2 and 3 & 4. Connect the framing light leads to the 12 V.AC secondary output on terminals 5 & 8.

SHAFT ENCODERS mount the the brackets adjacent to the film-driven sprockets located at the top and bottom of the main frame. The bracket mounting screws pass through slotted holes to allow adjusting the degree of belt tension.

THREADING

THREADING THE PROJECTOR correctly is one of the operator's most important responsibilities. The design of this projector makes no provision for correcting frame position after motor start, so the operator must exercise extreme care at this step.

THE MOTOR CONTROLLER includes a JOG switch which momentarily energizes the drive motor to advance a frame or two of film. Use the JOG switch, or inch the mechanism by hand, to bring both intermittent sprockets to their "locked" stage. Open the (6) detent arm assemblies to retract the sprocket shoes from the sprockets. The film gate can be opened to a slight degree by swinging the gate lever forward.

CLEAN ALL FILM-BEARING SURFACES prior to each threading procedure. Check rollers for free operation and remove film residue to prevent buildup.

THREAD THE FILM as illustrated. Center the picture frame over the opening of the aperture plate. Note the loop sizes at the intermittent sprockets. With the intermittents in their "locked" stages, the minimum (one-finger) loop is shown at the upper intermittent sprocket, and the maximum (two-finger) loop is shown at the lower intermittent sprocket. Close the film gate.

JOG OR INCH the mechanism to advance a few frames of film. Observe the film loops above and below the film gate. As the film feeds, the upper loop should grow to the maximum size as the lower loop reduces to minimum size. Check the aperture to verify correct framing. Run fingers over each sprocket to insure that the sprocket teeth are centered in the film perforations, and the film is centered across the sprocket face.

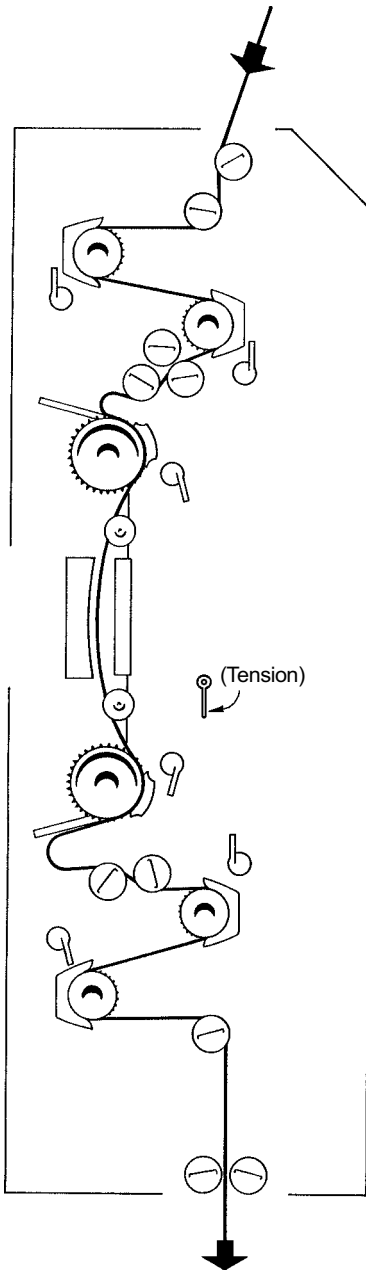

INITIAL OPERATION

IGNITE THE LAMPHOUSE, start the projector motor at projection speed, and open the lamphouse douser. Install the projection lens and move the lens inside the barrel until a sharply focused picture is projected. Tighten the lens clamp.

THE OPTIONAL LENS REDUCER (Part No. 22-60259), required for 72mm (outside) diameter lenses, should be attached to the lens prior to installation to the lens barrel. Tighten the (2) nylon set screws to secure the reducer to the lens.

OBSERVE THE PROJECTED PICTURE for steadiness and flatness of focal field. If the picture is unsteady, or if the film transport is excessively noisy, adjust the position of the film gate by moving the gate lever while observing the screen. If the movements have been correctly synchronized, the steadiest picture should produce the lowest transport noise.

VISIBLE STREAKING of lighter areas against a dark background is commonly called “travel ghost” and is most obvious during opening or closing credits and titles. This condition indicates that the shutter is not correctly timed. See the instructions regarding “Shutter Timing” in the following ADJUSTMENTS & REPLACEMENTS section.

THE POSITION OF THE FILM GATE is factory-set for a 0° (flat) projection angle. If the picture is difficult to focus because of a steep projection angle (i.e. in focus at the top of the screen, but out of focus at the bottom), the angle of the film gate can be shifted by loosening and re-setting the (2) eccentric brass cams above and below the gate mounting plate. Tilt the film gate until the picture is in focus top and bottom, and secure the cam mounting screws.

AN EXTREME SHIFT of the film gate may require a similar adjustment to the lens barrel. The knurled wheel above the lens barrel may be rotated to raise or lower the optical center of the lens barrel. Turning the wheel toward the front of the projector lowers the optical center, and turning the wheel toward the back of the projector raises the optical center.

FINE FOCUS CONTROL of the projection lens may change from day to day. A focus knob protrudes from the front of the projector for this adjustment.

MAINTENANCE

WITH PROPER MAINTENANCE, the CineKinetic Projector will deliver many years of trouble-free operation. Establishing a routine of regular cleaning and inspection requires little effort and will minimize downtime.

THE FILM PATH and all attendant film-wearing parts should be cleaned at least once daily. Using a typewriter brush, or a used toothbrush (with softened bristles), brush all sprocket teeth and remove any film residue or wax built up on the sprocket faces. Brush the inner surfaces of the sprocket shoes.

DISMOUNT THE FILM GATE and thoroughly clean the gate components using a clean lint-free cloth. Check the lateral guide rollers for free operation. Inspect all film-wearing parts and replace worn components as required. It is recommended to replace gate components in matched left and right pairs.

THE FILM GATE is easily dismounted by removing the (2) socket head screws and their washers and compression springs. Do not remove or re-position the brass cams above and below the film gate. The position of these cams will insure correctly locating the gate when re-installing.

STOP SCREWS, set at the factory, insure that the gate is correctly located when replaced. Slide the gate back toward the heat shield and aperture plate until the stop screws (see Figure 7, Item 17) touch the heat shield bracket.

OPEN THE GEAR COMPARTMENT DOOR and inspect the timing belts. If any of the belts exhibit wear (cracks, tears, eroded teeth), *replace all four*. See the detailed instructions in the following section.

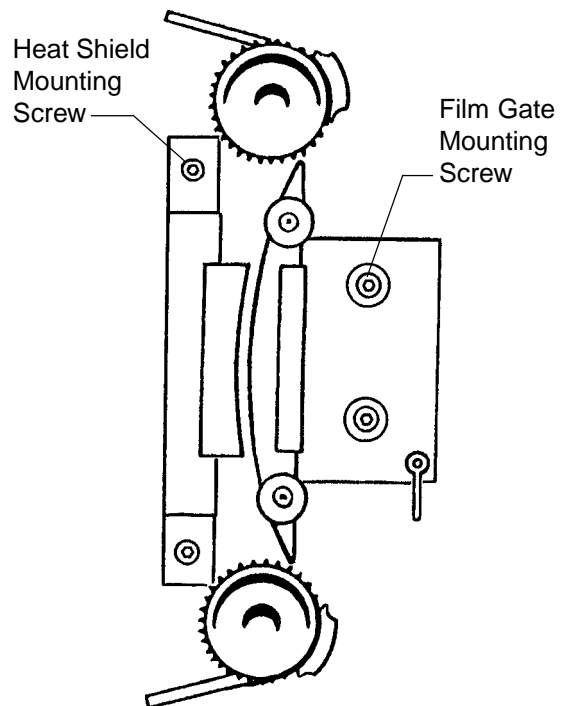

ADJUSTMENTS & REPLACEMENTS

ESTABLISHING A ROUTINE of regular maintenance will insure dependable operation of the CineKinetic 870 projector and prolong print life. All projector components are designed for long service. Those parts most subject to wear, such as film-bearing pads and shoes, mount to readily-accessible subassemblies for ease of field replacement with a minimum of downtime.

MOST PROCEDURES OUTLINED BELOW can be performed by field service personnel using common hand tools. A Spacer Gauge is supplied with each projector to simplify field alignment of lateral guide rollers. The Intermittent Movements, because of their complexity, are best returned to the factory for service and adjustments. The assembly and testing of this unit require unique fixturing utilized by specially-trained technicians. Other items requiring factory assembly are so noted in the Parts List.

LUBRICATION

1. INITIAL OILING: Use only the special oil supplied with the projector (Ballantyne Part No. 21-98126). The CineKinetic projector is shipped with all oil reservoirs filled. Remove the oil fill plugs on the intermittent movements and on the top of the shutter gearbox and verify that the oil level reaches the fill ports. Add oil as required.
2. DAILY OPERATION: When the projector motor is energized, the oil level will rise and become visible in the (3) breather tubes connected to the movements and to the shutter gearbox. Air bubbles will be visible in the shutter gearbox sight glass. *Never* operate the CineKinetic projector without oil.
3. CHANGE THE OIL after six months of normal operation. Brass drain plugs are located on the bottoms of the intermittent movement cases and on the bottom of the shutter gearbox adjacent to the driven gear. After draining the oil, carefully clean up any spillage, and replace the drain plugs. Fill the reservoirs with 21-98126 oil.
4. The horizontal sprocket shaft assemblies include sealed, pre-lubricated ball bearings. If these assemblies are dismantled in the course of replacing component parts, add a drop or two of light machine oil to the inner races of the ball bearings before rebuilding the assembly.

SHUTTER TIMING

1. Rotate the lower intermittent flywheel by hand while observing the lower intermittent sprocket. After the intermittent steps to a "locked" stage, place a stationary object next to one sprocket tooth

SHUTTER TIMING (continued)

2. Slowly rotate the intermittent flywheel while watching the marked sprocket tooth. Allow the intermittent sprocket to advance *four teeth*, and stop.
3. Loosen the (2) socket head clamping screws in the shutter hub, allowing the shutter to rotate freely on the shutter shaft as the mechanism remains stationary.
4. Turn the shutter on its shaft until one shutter blade completely covers the picture aperture. While the mechanism remains stationary, tighten the (2) shutter hub clamping screws.
5. Inch or “jog” the projector and make certain that the shutter blade does not touch the sheet metal cabinet or the stainless steel heat shield.
- 6 Repeat Steps 1 & 2 to verify correct shutter timing.

REPLACEMENT OF SPROCKET SHOES

Always replace sprocket shoes in matched pairs. Intermittent sprocket shoes and feed sprocket shoes are not interchangeable. Furthermore, feed sprocket shoes are paired as *inboard* and *outboard* sets.

1. Close the sprocket shoe detent assembly against the face of the sprocket. Using a 90°, 1/8" allen key, loosen the 1/4-20 set screw at the base of the detent assembly and remove the detent assembly from the main frame.
2. Dismount the worn shoes and replace with new shoes. Note intermittent shoes are interchangeable (inboard and outboard), whereas feed sprocket shoes are undercut and must be installed as either inboard or outboard (undercut to the center of the sprocket).
3. Return the detent assembly to its main frame mounting bracket. Using a length of scrap film, set the gap between the replacement shoes and the face of the sprocket: (1) film thickness for intermittent shoes or (2) film thicknesses for feed sprocket shoes. When the gap is set, tighten the set screw to secure the detent assembly to the main frame bracket.
4. Open and close the detent assembly to check for correct operation. Observe the gap between the sprocket shoe and the sprocket face and correct as required.

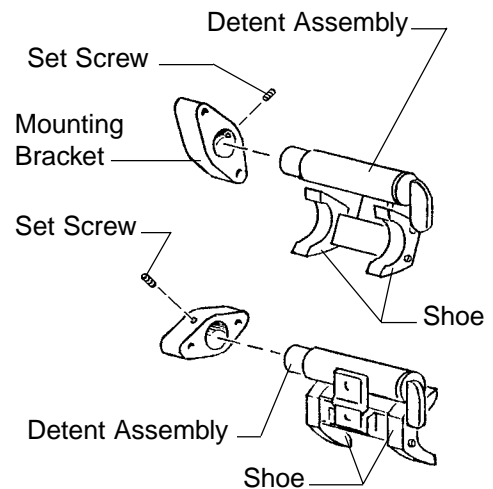

FEED SPROCKET REPLACEMENT

1. Replace sprockets one at a time. Alignment of replacement sprockets must be made relative to the position of existing sprockets.
2. Open the sprocket shoe detent assembly. Loosen the set screw in the center of the sprocket and slide the worn sprocket from the shaft.
3. Install the replacement sprocket. Using a straightedge, such as a six-inch machinist's scale, align the outside edge of the replacement sprocket to the outside edge of the adjacent feed sprocket. Tighten the sprocket set screw.
4. Using a length of scrap film, verify the (2) film thickness gap between the sprocket shoe and the face of the replacement sprocket. Correct spacing as required.

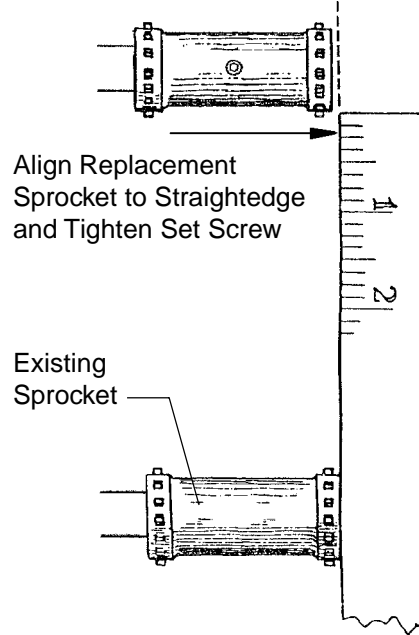

INTERMITTENT SPROCKET REPLACEMENT

1. Using a 1/16" allen key, remove the (2) button head screws and dismount the film stripper/loop chute located adjacent to the intermittent sprocket. Rotate an intermittent flywheel to index the movement to a "locked" stage with the head of the sprocket mounting screw accessible.
2. Using a 3/32" allen key. Loosen, but do not remove, the brass set screw securing the thumb screw at the end of the outboard bearing arm. Loosen the thumb screw.
3. Dismount the outboard bearing cap by removing the (2) socket head cap screws using a 5/32" allen key.
4. Remove the intermittent sprocket mounting screw and hexnut. Slide the worn sprocket off the intermittent shaft.
5. Slide the replacement sprocket onto the intermittent shaft. Install, but do not tighten, the sprocket mounting hardware (screw and hexnut).
6. Install the outboard bearing cap to the end of the outboard arm. Gradually tighten the (2) socket head mounting screws while rotating the intermittent flywheel to allow the bearing to center on the intermittent shaft.
7. Tighten the thumb screw fingertight only to remove end play from the outboard bearing. Secure this setting by tightening the brass set screw. NOTE: Do not use pliers or any hand tool to tighten the thumbscrew beyond fingertight. Overtightening the thumb screw can lead to intermittent damage.
8. Thread a length of scrap film into the film gate between the intermittent and the lateral guide rollers. Slide the intermittent sprocket in and out until the film lies flat on the gate runners with the perforations centered on the sprocket teeth. Verify correct framing and securely tighten the sprocket mounting screw and hexnut.
9. Install the loop chute.

TIMING BELT REPLACEMENT

It is recommended that the four drive belts be replaced after six months of normal operation. Since all four belts are subject to the same wear, *all four* should be replaced at the same time. The (2) belts driving the (customer supplied) shaft encoders should be inspected for wear or cracks, and replaced if required.

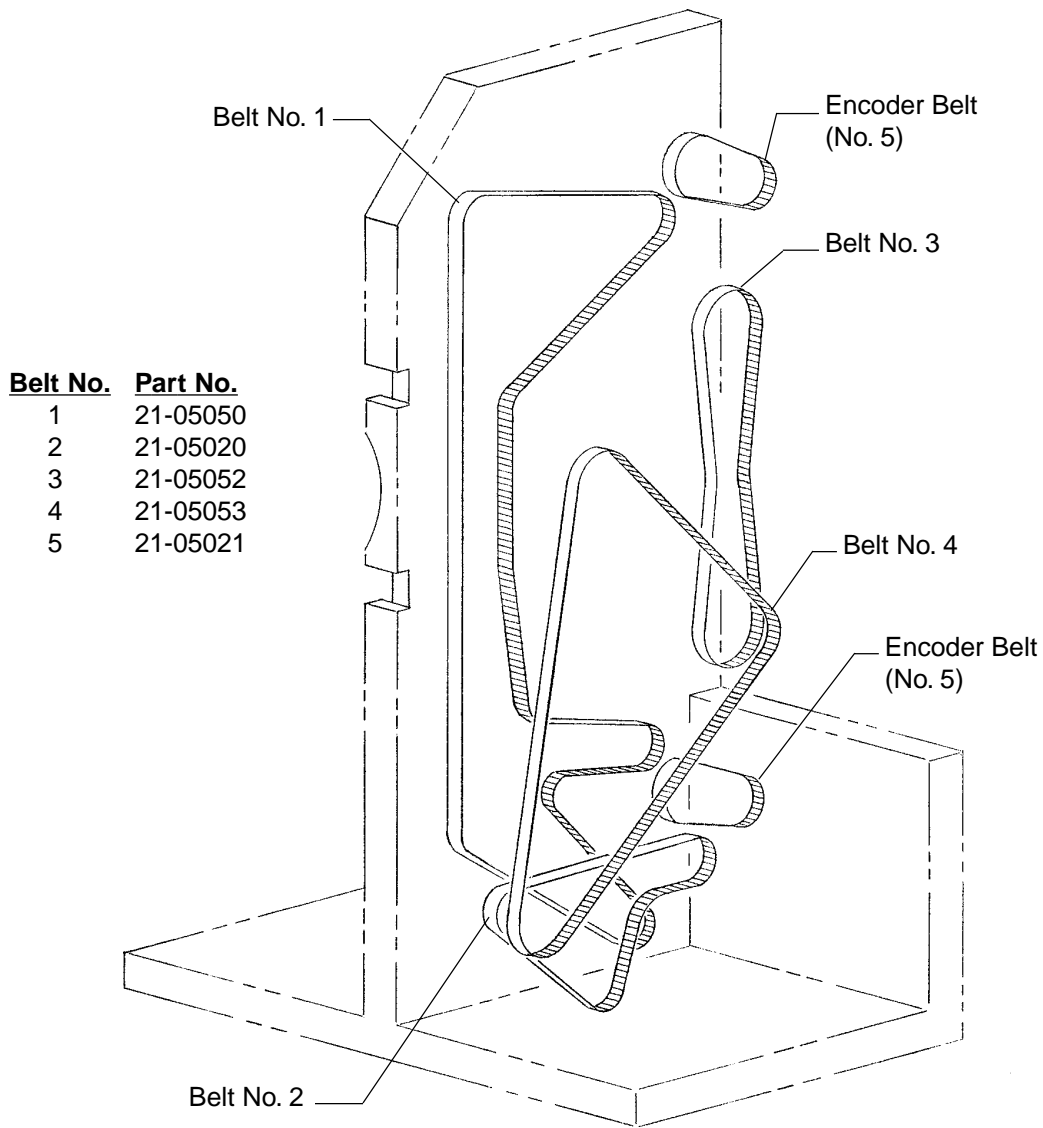

TIMING BELT REPLACEMENT (continued)

REMOVAL:

1. Loosen the belt tensioner below the drive motor and remove the Number 4 Belt from the motor drive pulley, the lower intermittent pulley, and the shutter gearbox driven pulley.
2. Using a 5/32 inch allen key, dismount one of the (2) idler pulleys between the two intermittent movements and remove the intermittent timing belt (No. 3).
3. Dismount the No. 2 Belt tensioner pulley by loosening the shaft set screw and withdrawing the pulley shaft. Note the assembly sequence of spacers on the pulley shaft and re-assemble in the same sequence.
4. Loosen the socket head screw mounting the No. 1 Belt tensioner arm. With belt tension relieved, remove the (4) socket head screws securing the jackshaft assembly to the projector base plate and dismount the jackshaft. *Do not disassemble the jackshaft.* Remove the No. 1 Belt.

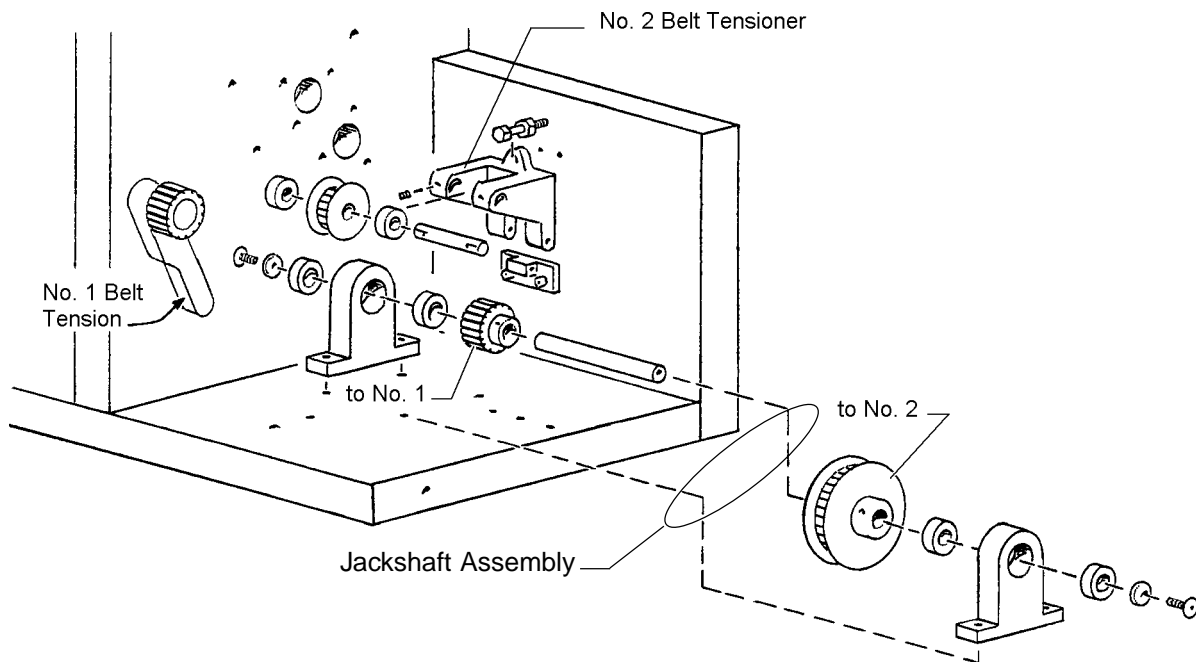

INSTALLATION:

1. Re-install the jackshaft after first looping the replacement No. 1 Belt around the smaller pulley. Thread the belt through its drive path: (5) timing belt pulleys and (4) idler pulleys. Apply belt tension by pressing the tensioner arm as shown, and tighten the tensioner arm mounting screw.
2. Re-install the No.2 Belt tensioner pulley after first looping the replacement No. 2 Belt around the pulley. Duplicate the assembly sequence, replacing all spacers on the shaft with the pulley.
3. Loop the replacement *No. 4 Belt* around the inner drive motor pulley.

TIMING BELT REPLACEMENT (continued)

4. Thread the replacement No. 2 Belt to its (4) timing belt pulleys. Do not set the tensioner until first installing the No. 4 belt (following).
5. Replace the idler pulley between the intermittent movements. Install the No. 3 Belt as instructed in the SYNCHRONIZATION OF INTERMITTENT MOVEMENTS procedure immediately following.
6. Run the No. 4 Belt, from the drive motor (Step 3), around the shutter gearbox driven pulley and the outer timing belt pulley on the lower intermittent movement. Apply belt tension using the tensioner below the drive motor..
7. Time the shutter.

SYNCHRONIZATION OF INTERMITTENT MOVEMENTS

1. Rotate the intermittent flywheels and step both movements to a “locked” stage.
2. Loosen the screws mounting idler pulleys “A” and “B.” Set the pulleys allowing a 2.125 to 2.25 inch (54 to 57mm) gap as measured center-to-center at the screw heads. Install the replacement timing belt between the two movements.
3. Loosen the (6) socket head screws “C” and rotate both movements until tension is applied to the timing belt. Tighten the socket head screws “C.”
4. Thread a length of scrap film between the two intermittent sprockets. Loosen the lower intermittent sprocket mounting hardware. With the intermittent movement stationary, rotate the intermittent sprocket to align the lower frame line on the film to the bottom of the aperture opening. Make certain that the sprocket is still in horizontal alignment (in-and-out), and re-tighten the sprocket mounting hardware. Remove the film.

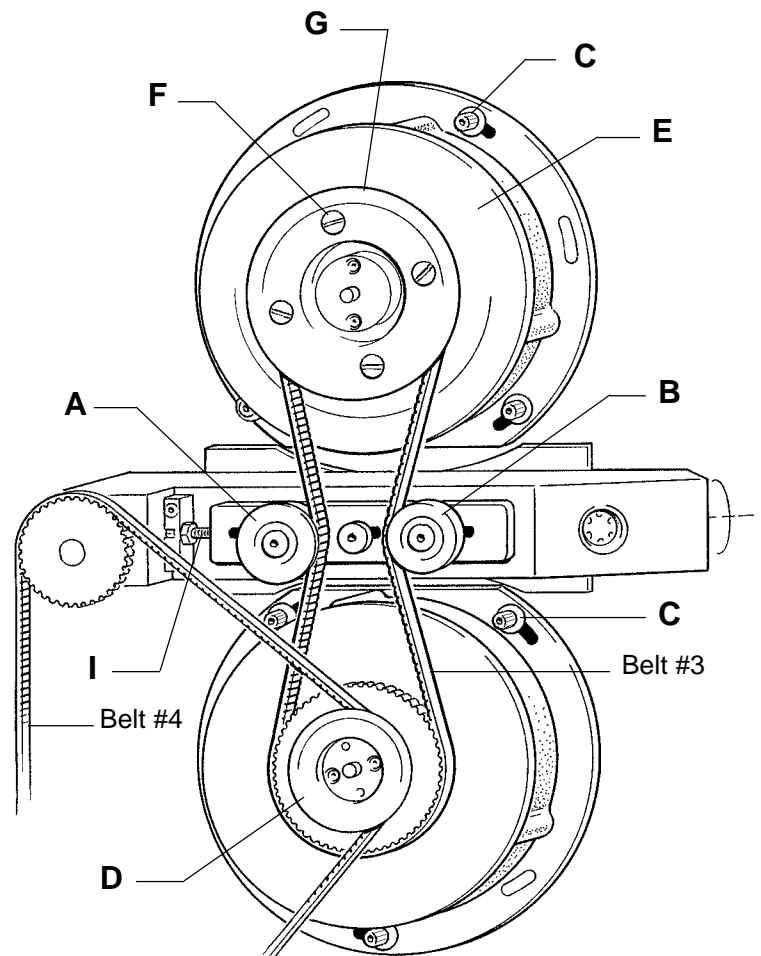

SYNCHRONIZATION OF INTERMITTENT MOVEMENTS (continued)

5. Rotate lower intermittent flywheel "D" while observing the lower intermittent sprocket. Rotate flywheel "D" until the lower intermittent sprocket *begins* its pulldown step. Stop the movement at this point and remove the timing belt.
6. Rotate the upper flywheel "E" until the upper intermittent sprocket *begins* its pulldown step. Stop the movement at this point, and re-install the timing belt.
7. With both intermittent sprockets stationary, loosen the (4) pan head screws "F." Hold flywheel "E" to prevent motion, and rotate pulley "G" to take up the belt slack. Secure the (4) screws "F."
8. Thread a length of scrap film between the two intermittent sprockets. Move gate lever "H" to the center of its travel. Loosen the mounting screw and locknut securing the upper intermittent sprocket. Rotate the upper intermittent sprocket until the film slack has been taken out.
9. Rotate both intermittent movements, and observe film tension at the gate. If the film gains slack at pulldown, loosen idler pulley "B" and move it toward the rear (toward shutter). Move idler "A" into the belt to take up belt slack.
10. If the film draws taut at pulldown, loosen idler pulley "A" and move it slightly forward (away from shutter). Move idler pulley "B" into the belt to take up belt slack.
11. Pulleys "A" and "B" can be moved simultaneously for fine adjustment by loosening the shoulder screw between the two pulleys and tightening or loosening the stop screw "I." Tighten the locknut after making fine adjustment to fix the setting.

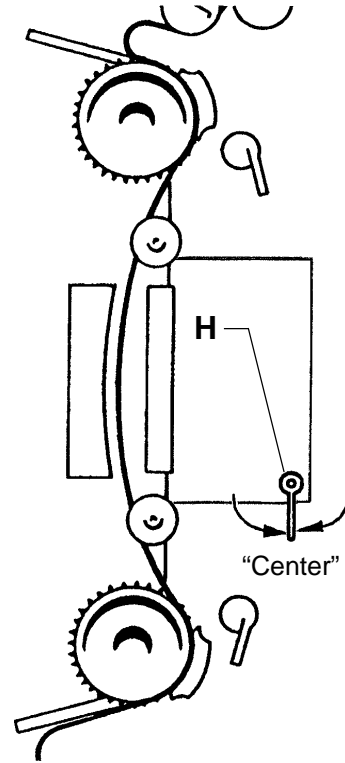

REPLACEMENT OF INTERMITTENT MOVEMENT

The upper and lower intermittent movements differ from one another in the location of oil fill and drain plugs, and in the configuration of driven pulleys. Specify UPPER or LOWER movement when ordering a replacement unit.

1. Remove the film stripper/loop chute from the intermittent sprocket outboard arm.
2. Dismount one of the two idler rollers (previous page, Items "A" or "B") and remove the timing belt. If replacing lower intermittent, loosen the belt tensioner below the drive motor to relax the drive belt tension.
3. Remove the (3) socket head 1/4-20 screws (previous page, Item "C"). Dismount the movement.
4. Install replacement movement. Synchronize the movements (see preceding), check belt tension, and time the shutter.

REPLACEMENT OF FILM GATE COMPONENTS

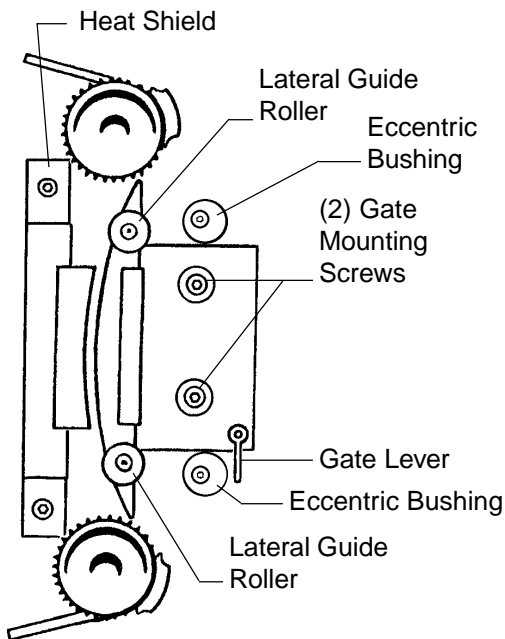

1. Carefully inspect the film-wearing surfaces on the gate. Gate runners should be parallel; no visible indications of undercutting across the flat surfaces. Lateral guide rollers should not display any cuts on their inner surfaces. Replace worn components as required.
2. Dismount the film gate by removing the (2) socket head mounting screws and their washers and compression springs. DO NOT alter the positions of the eccentric bushings or the stop screws (see Figure 7, Item 17).
3. Gate runners are secured to the gate bracket with (2) screws each (see Figure 7, Item 9). Replace gate runners in *matched pairs* (inboard and outboard) to insure even wear.
4. Each lateral guide roller is secured by a locknut (see Figure 7, Item 5). Lateral guide rollers are interchangeable, and may be rotated left-to-right to distribute wear.
5. Align the lateral guide rollers before installing the replacement gate runners. Place the film gate assembly on the alignment gauge with the runner slots facing the upright posts of the gauge. Loosen the lateral guide roller shaft clamping screws (see Figure 7, Item 13). Slide the guide roller shaft to allow the inner surfaces of the outboard guide rollers to rest against the machined surfaces on the tops of the upright posts. Re-tighten the guide roller shaft clamping screws.
6. See Figure 7, Items 15 & 16 before replacing gate runners. The right (outboard, Item 15) runner is identified by a hole drilled through the runner near the optical center. The outer sides of both runners are undercut top and bottom to allow clearance for the lateral guide rollers. Replace the runners as illustrated, and secure the mounting hardware (Item 9). Check the outboard lateral guide rollers for free movement, and adjust the outboard runner as required.
7. Re-install the film gate to the film compartment. Place the gate bracket between the eccentric bushings with the aligning pin (Figure 7, Item 18) in its slot. Slide the gate bracket back to rest the stop screws (Figure 7, Item 17) against the heat shield bracket.

Outboard Lateral Guide Rollers to rest on these machined surfaces

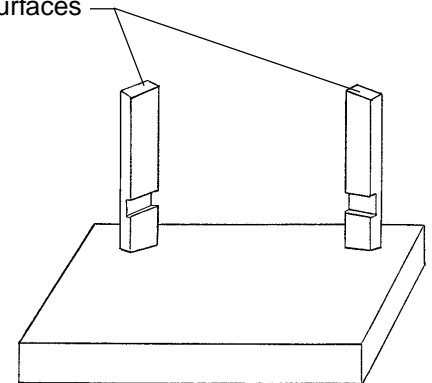

GATE ALIGNMENT GAUGE
Part No. 22-21814

FIGURE 1

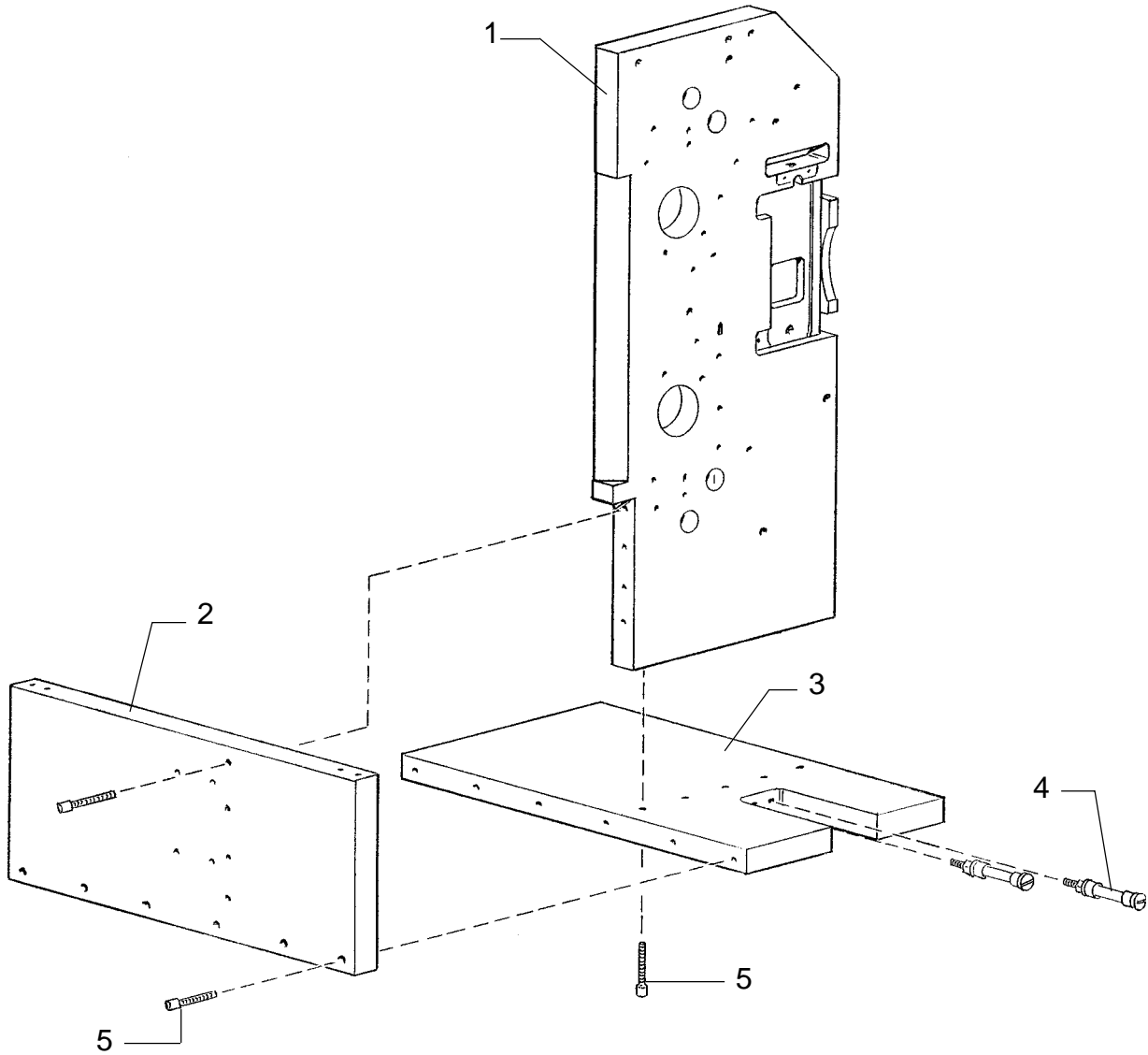

<u>Item</u>	<u>Part No.</u>	<u>Description</u>
1	22-21774	Main Frame Plate
2	21-39033	Back Plate
3	21-39032	Base Plate
4	22-60699	Roller Assembly
5	41-51233	Screw, 3/8-16 x 1-1/4" Socket Head

FIGURE 2

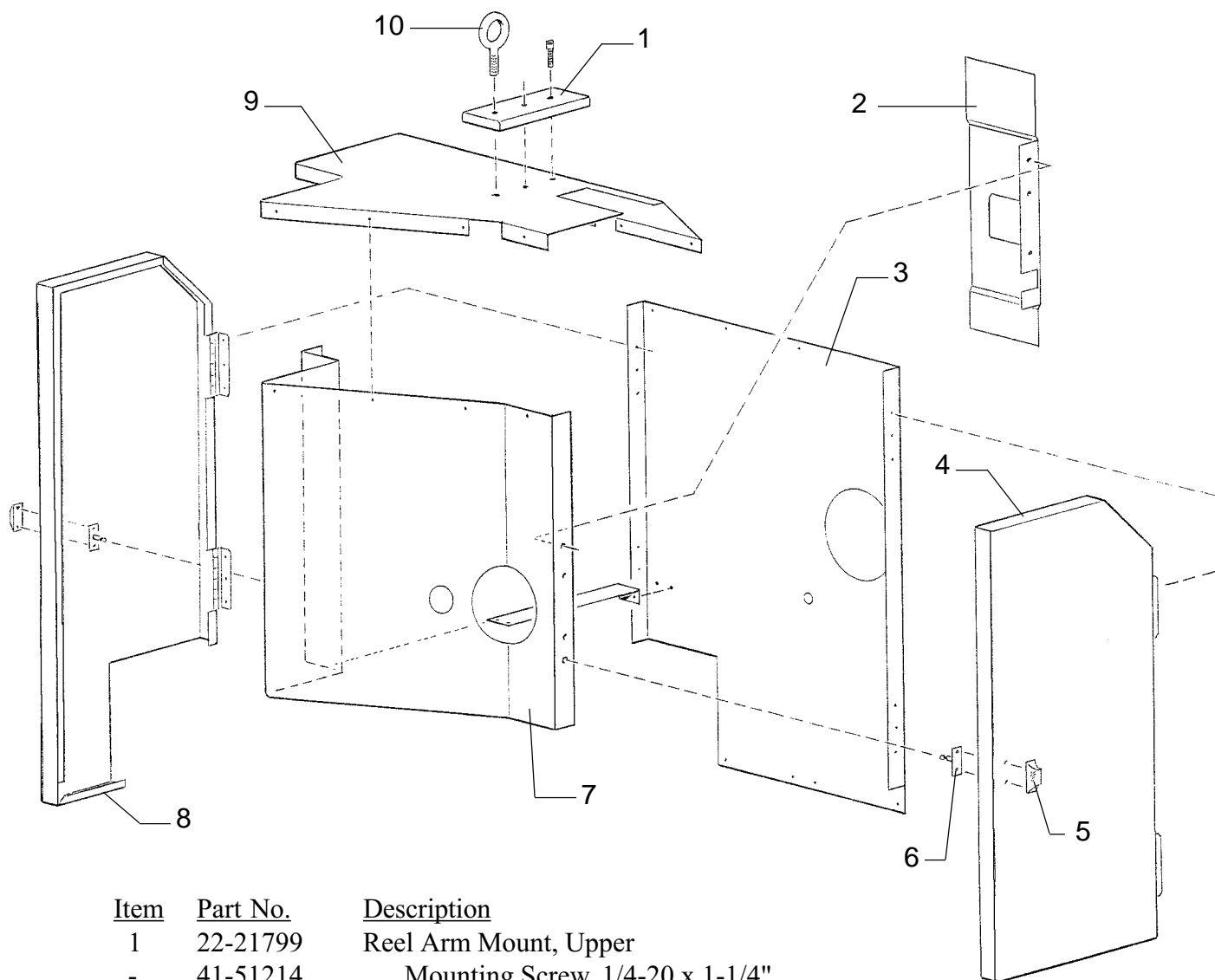

<u>Item</u>	<u>Part No.</u>	<u>Description</u>
1	22-21799	Reel Arm Mount, Upper
-	41-51214	Mounting Screw, 1/4-20 x 1-1/4"
2	22-41265	Heat Shield
-	41-51544	Mounting Screw, 6-32 x 1/4" Black Oxide
3	22-41233	Front Panel
-	41-51110	Mounting Screw, 10-32 x 1/2" Phillips
4	22-41241	Access Door, Film Compartment
5	31-28001	Door Handle
6	22-40072	Door Catch
7	22-41236	Back Panel & Shutter Guard
8	22-41242	Access Door, Gear Compartment
9	22-41237	Top Cover
10	21-51034	Eye Bolt, 1/2-13 (replace with 41-51753 Cap Screw)

FIGURE 3

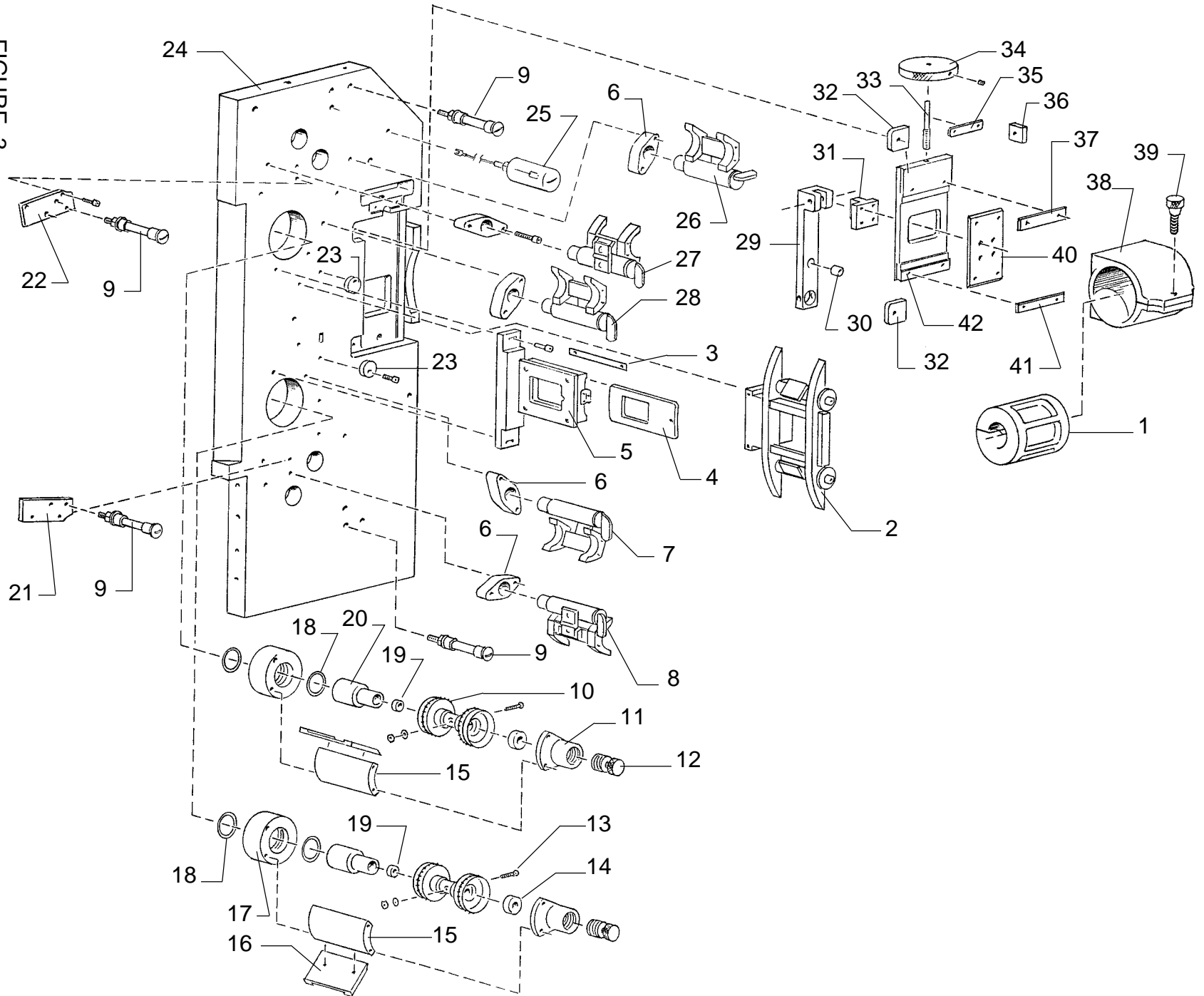

PARTS LIST

Figure 3

<u>Item</u>	<u>Part No.</u>	<u>Description</u>
1	22-60259	Lens Reducer, 4" to 72mm (Optional)
2	22-60706	Film Gate Assembly (see Figure 7)
3	22-41260	Aperture Retainer Plate
-	22-41259	Spacer Plate, Aperture Retainer
-	41-51012	Mounting Screw, 4-40 x 1/4" Button Head
4	21-41261	Aperture Plate
5	21-41262	Heat Shield Plate
5	22-21817	Heat Shield & Aperture Mounting Bracket
-	51-98211	Spring & Plunger Assembly
-	21-56001	Heat Shield Spacer (4 req'd.)
-	41-51274	Heat Shield Mounting Screw, 10-30 x 1/2" Button Head
6	21-98653	Detent Mount
-	41-51220	Mounting Screw, 1/4-20 x 5/8"
-	41-51178	Detent Set Screw, 1/4-20 x 1/4"
7	22-60704	Lower Intermittent Sprocket Shoe Detent Assembly*
8	22-60702	Lower Feed Sprocket Shoe Detent Assembly*
9	22-60699	Guide Roller Assembly
10	21-59020	Intermittent Sprocket
11	21-98647	Outboard Bearing Housing
-	41-51607	Mounting Screw, 10-32 x 5/8"
12	22-20852	Thumb Screw, Outboard Bearing
-	41-51250	Set Screw, 10-32 x 1/4" Brass
13	41-51282	Intermittent Sprocket Retaining Screw
-	41-35044	Hexnut, FlexLock
14	21-04008	Ball Bearing
15	21-98648	Spacer Arm, Outboard Bearing
16	21-98679	Film Stripper/Loop Chute
-	41-51391	Mounting Screw, 4-40 x 3/8" Button Head
17	21-98630	Housing, Starwheel Bushing
18	21-48017	O-Ring
19	21-36016	Oil Seal
20	21-07029	Starwheel Bushing (Order 21-52009)
21	21-06042	Roller Mounting Plate, Lower
-	41-51208	Mounting Screw, 10-32 x 1/2"
	*	<i>See Figure 8</i>

PARTS LIST, Figure 3 (continued)

<u>Item</u>	<u>Part No.</u>	<u>Description</u>
22	21-06041	Roller Mounting Plate, Upper
-	41-51208	Mounting Screw, 10-32 x 1/2"
23	21-98629	Eccentric Cam, Brass
-	41-51220	Mounting Screw, 1/4-20 x 5/8"
24	22-21774	Main Frame Plate (see Figure 1, Item 1)
25	82-70047	Light Assembly, Film Compartment
-	82-70008	Light Shield, Glass
-	LP-0122	Bulb, 12 V.AC
-	82-70030	Socket Assembly
-	81-61012	Toggle Switch
-	PE-1299	Switch Plate, "On-Off"
-	81-64006	Stepdown Transformer, 120-12 V.AC (not shown)
26	22-60701	Feed Sprocket Shoe Detent Assembly*
27	22-60702	Feed Sprocket Shoe Detent Assembly*
28	22-60703	Upper Intermittent Sprocket Shoe Detent Assembly*
29	21-98651	Focus Transfer Arm, Lens Barrel (see Figure 4, Item 24)
30	21-04041	Pivot Bushing, Bronze
31	21-98658	Focus Bar
-	41-51207	Mounting Screw, 10-32 x 1/2" Flat Head
32	21-98655	Inner Gib
33	21-52039	Threaded Shaft, Lens Height Adjust
34	21-28025	Knurled Knob, Lens Height Adjust
-	41-51189	Set Screw, 1/4-20 x 3/4"
35	21-98057	Shaft Retainer
36	21-98656	Outer Gib
37	21-98636	Side Gib, Upper
38	21-98664	Lens Barrel
39	21-28026	Knurled Cap, Lens Clamping Screw
-	41-51454	Headless Set Screw, 1/4-20 x 1-1/4"
40	21-39029	Lens Barrel Mounting Plate
41	21-98637	Side Gib, Lower
42	21-39026	Side Plate, Lens Mount
	*	<i>See Figure 8</i>

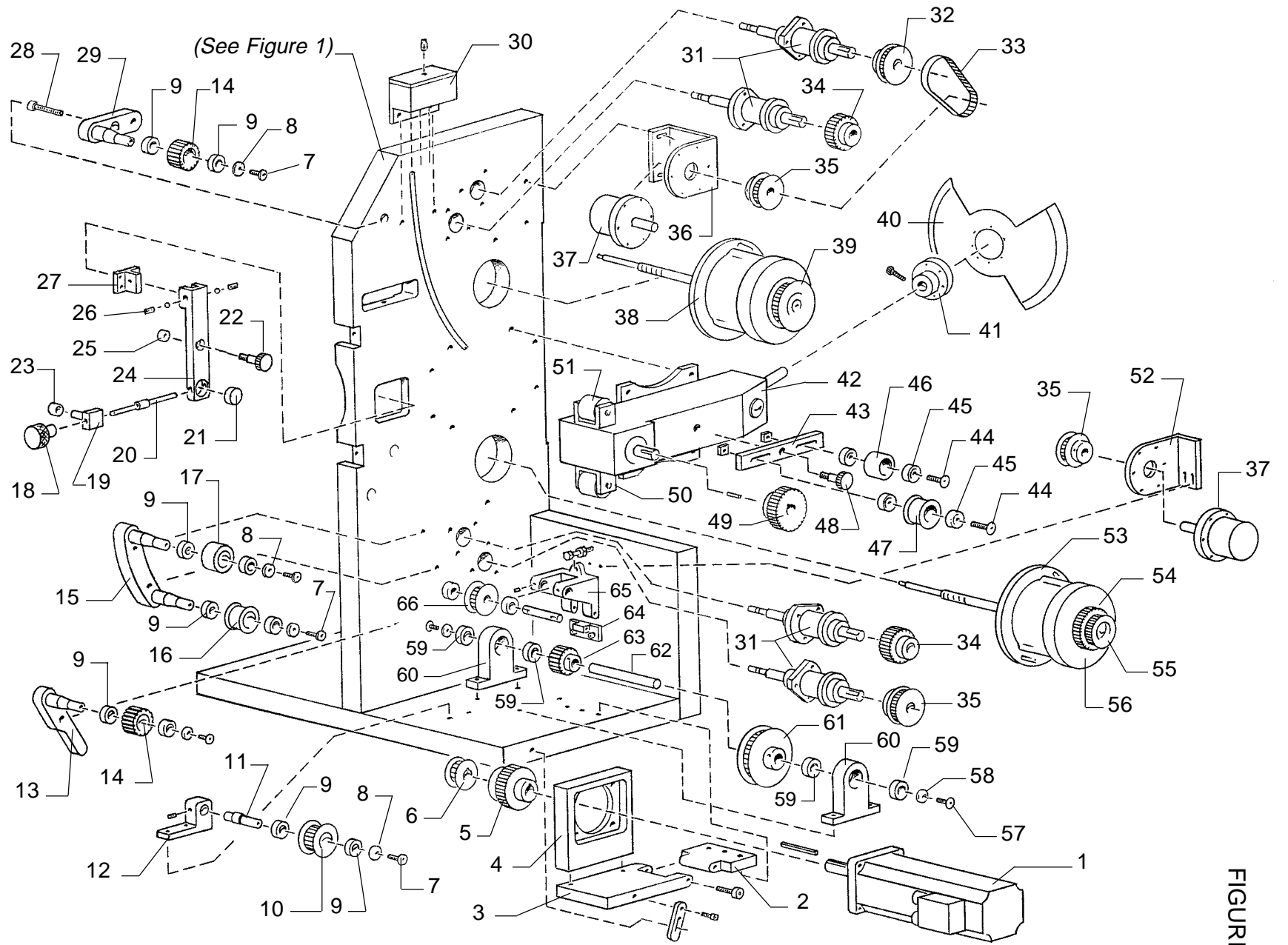

FIGURE 4

PARTS LIST

Figure 4

<u>Item</u>	<u>Part No.</u>	<u>Description</u>
1	--	Drive Motor (by Customer)
2	21-98632	Base Plate, Drive Motor Mount
-	41-51229	Mounting Screw, 5/16-18 x 1"
3	21-39031	Pivoting Plate, Drive Motor Mount
-	21-51027	Pivot Shoulder Bolt (to Item 2)
-	21-98633	Link, Belt Tensioner
-	41-51222	Link Screws, 1/4-20 x 3/4"
4	21-98631	Motor Face Plate
-	41-51222	Mounting Screw, 1/4-20 x 3/4"
5	22-21746	Drive Pulley
6	22-21810	Drive Pulley
7	41-51595	Screw, 10-32 x 1/2" Button Head
8	41-70023	Washer, #10
9	21-04023	Ball Bearing
10	22-21809	Pulley
11	21-52027	Pulley Shaft
12	21-06003	Pulley Bracket
-	41-51178	Set Screw, Pulley Shaft
-	41-51223	Mounting Screw, 1/4-20 x 1"
13	21-62016	Lever, Belt Tensioner
-	41-51223	Mounting Screw, 1/4-20 x 1"
-	21-41002	Pulley Shaft
-	41-51223	Shaft Mounting Screw, 1/4-20 x 1"
14	22-21804	Pulley
15	21-98650	Arm, Idler Pulleys
-	41-51223	Mounting Screw, 1/4-20 x 1"
-	21-41002	Shaft, Idler Pulley
-	41-51223	Shaft Mounting Screw, 1/4-20 x 1"
16	21-43006	Flanged Idler Pulley
17	21-45005	Idler Pulley
18	21-28005	Focus Knob
19	21-98634	Focus Shaft Bearing Block
20	21-51025	Focus Screw
21	21-35011	Focus Bearing
22	21-51027	Shoulder Bolt, 3/8" x 1/2"

PARTS LIST, Figure 4 (continued)

<u>Item</u>	<u>Part No.</u>	<u>Description</u>
23	21-04041	Bushing (2 each)
24	21-98651	Focus Transfer Arm
25	21-04041	Bronze Bushing
26	41-51368	Set Screw, 5/16-18 x 1/4"
-	51-04010	Steel Ball, 1/4" Hardened
27	21-98658	Pivot Bar, Focus Arm
-	41-51207	Mounting Screw, 10-32 x 1/2" Flat Head
28	41-51344	Screw, 1/4-20 x 1-1/4"
29	21-98677	Bracket, Pulley Shaft
-	21-41002	Shaft
-	41-51223	Shaft Mounting Screw, 1/4-20 x 1"
30	21-98676	Oil Overflow Reservoir
-	41-51209	Mounting Screw, 10-32 x 5/8"
-	21-29025	Lid, Oil Reservoir
-	41-51394	Lid Mounting Screw, 4-40 x 3/8"
-	22-20614	Breather Plug, Nylon
-	22-60692	Oil Line, Upper Intermittent Movement
-	22-60692	Oil Line, Shutter Gearbox
-	22-60692	Oil Line, Lower Intermittent Movement
-	21-98023	Hose Barb, Brass
31	22-60708	Horizontal Sprocket Shaft Assembly (see Figure 6)
-	41-51209	Mounting Screw, 10-32 x 5/8"
32	22-21797	Encoder Drive Pulley
33	21-05021	Encoder Drive Belt
34	22-21807	Sprocket Shaft Driven Pulley
35	22-21798	Encoder Driven Pulley
36	22-60694	Upper Encoder Bracket Assembly
-	41-51209	Mounting Screw, 10-32 x 5/8"
37		Encoder (by Customer)
38	22-60690	Upper Intermittent Movement Assembly
-	41-51223	Mounting Screw, 1/4-20 x 1"
39	22-21811	Driven Pulley (incl. with Item 38)
-	22-41150	Pulley Flange
-	22-21794	Intermittent Flywheel (incl. with Item 38)

PARTS LIST, Figure 4 (continued)

<u>Item</u>	<u>Part No.</u>	<u>Description</u>
40	22-60008	Shutter Blade Assembly (incl. Item 41)
41	21-98626	Shutter Hub
-	41-51097	Blade Mounting Screw, 10-32 x 3/8"
-	41-51213	Hub Clamping Screw, 10-32 x 1"
42	22-60709	Shutter Gearbox Assembly (see Figure 5)
-	41-51209	Mounting Screw, 10-32 x 5/8"
43	21-98661	Slide Bar, Idler Rollers
44	41-51493	Screw, 1/4-20 x 3/8" Button Head
-	21-35012	Square Nut
45	21-04023	Ball Bearing
-	21-56006	Bearing Spacer
-	21-98660	Bearing Shaft
-	41-51190	Set Screw, 1/4-20 x 1"
46	21-43005	Idler Pulley
47	21-43014	Idler Pulley, Flanged
-	21-56006	Bearing Spacer
-	21-98660	Bearing Shaft
48	21-51027	Shoulder Bolt, 3/8" x 1/2"
49	21-21808	Shutter Gearbox Driven Pulley
-	21-27009	Key
-	41-51187	Set Screw, 1/4-20 x 1/2"
50	21-98635	Bypass Roller Bracket
-	41-51207	Mounting Screw, 10-32 x 1/2" Flat Head
-	41-51602	Set Screw, Roller Shaft; 6-32 x 1/4"
51	21-49007	Bypass Roller
-	21-04023	Ball Bearing
-	21-52022	Roller Shaft
52	22-60693	Lower Encoder Bracket Assembly
-	41-51209	Mounting Screw, 10-32 x 5/8"
53	22-60691	Lower Intermittent Movement
-	41-51223	Mounting Screw, 1/4-20 x 1"
54	22-21816	Pulley Assembly (incl. with Item 53)

PARTS LIST, Figure 4 (continued)

<u>Item</u>	<u>Part No.</u>	<u>Description</u>
55	22-21816	Pulley Assembly (incl. with Item 53)
56	22-21794	Intermittent Flywheel (incl. with Item 53)
57	41-51575	Screw, 14/-20 x 1/2" Button Head
58	21-70032	Bevel Washer
59	21-04006	Ball Bearing
60	21-98638	Jackshaft Bracket
-	41-51223	Bracket Mounting Screw, 1/4-20 x 1"
61	22-21784	Pulley
-	41-51187	Set Screw, 1/4-20 x 1/2"
62	21-52026	Pulley Shaft
63	22-21805	Pulley
-	21-37038	Roll Pin, 1/8"
64	21-98649	Mounting Bracket, Belt Tensioner
-	41-51223	Mounting Screw, 1/4-20 x 1"
65	21-06002	Tensioner Arm
-	21-52029	Pivot Shaft (to Item 64)
-	21-52028	Roller Shaft (to Item 66)
-	41-51173	Shaft Set Screw, 8-32 x 1/4"
-	41-51225	Tensioning Screw, 1/4-20 x 1-1/2"
-	41-36016	Locknut, 1/4-20 Hex
66	22-21809	Pulley
-	21-04023	Ball Bearing

See Page 9 for Timing Belt Part Numbers.

FIGURE 5

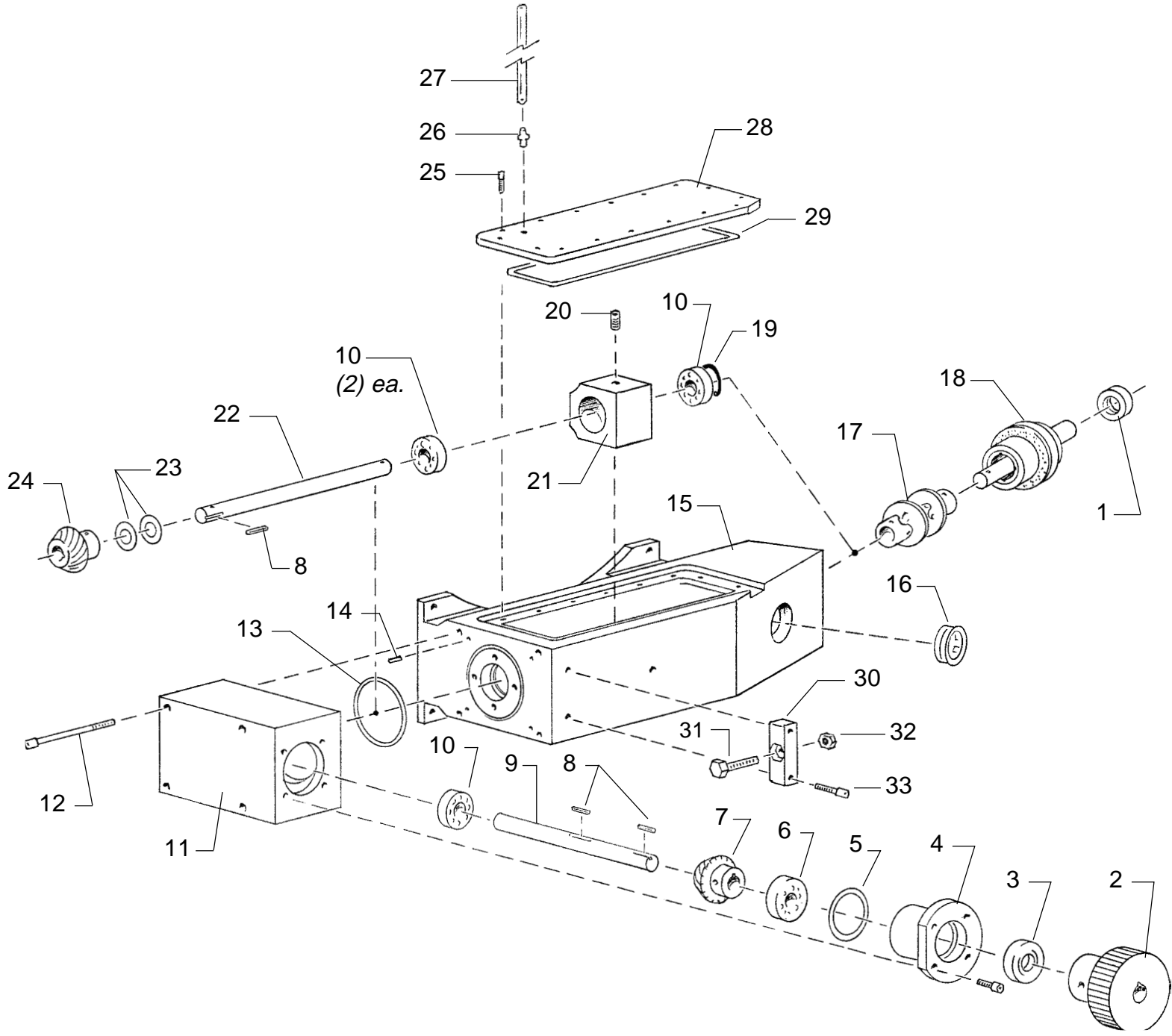

PARTS LIST

Figure 5

<u>Item</u>	<u>Part No.</u>	<u>Description</u>
1	21-36013	Oil Seal
2	22-21808	Gearbox Driven Pulley
3	21-36013	Oil Seal
4	21-98638	Bearing Housing
-	41-51208	Mounting Screw, 10-32 x 1/2"
5	21-48033	O-Ring
6	21-04006	Ball Bearing
7	21-23056	Bevel Gear
8	21-27009	Key
9	21-52021	Gear Shaft
10	21-04005	Ball Bearing
11	21-98663	Drive Transfer Housing
12	41-51214	Screw, 10-32 x 1-1/4"
13	21-48032	O-Ring Cord, 1/8" x 3-5/32"
14	21-37003	Dowel Pin, 3/16" x 7/8"
15	21-98670	Gearbox Housing
16	51-98200	Oil Sight Glass
17	21-98673	Universal Joint
18	22-60700	Shutter Shaft & Bearing Assembly
19	21-48012	Snap Ring, 7/8" O.D.
20	41-51357	Set Screw, 10-32 x 1/2"
21	21-98669	Bearing Block
22	21-52017	Gear Shaft
23	41-70024	Spacer Washer (qty. as req'd.)
24	21-23057	Bevel Gear
25	41-51565	Screw, 4-40 x 3/8"
26	21-98023	Hose Barb, Brass
27	21-26005	Oil Line
28	21-29024	Lid, Gearbox Assembly
29	21-48032	O-Ring Cord, 1/8" x 14-1/2"
30	21-98662	Block, Fine Adjust Screw
31	21-51026	Fine Adjust Screw, Sync Belt
32	41-35016	Locknut, 1/4-20 Hex
33	41-51209	Mounting Screw, 10-32 x 5/8"

NOT SHOWN

21-40249 Pipe Plug, Brass (Oil Fill, Oil Drain)

FIGURE 6

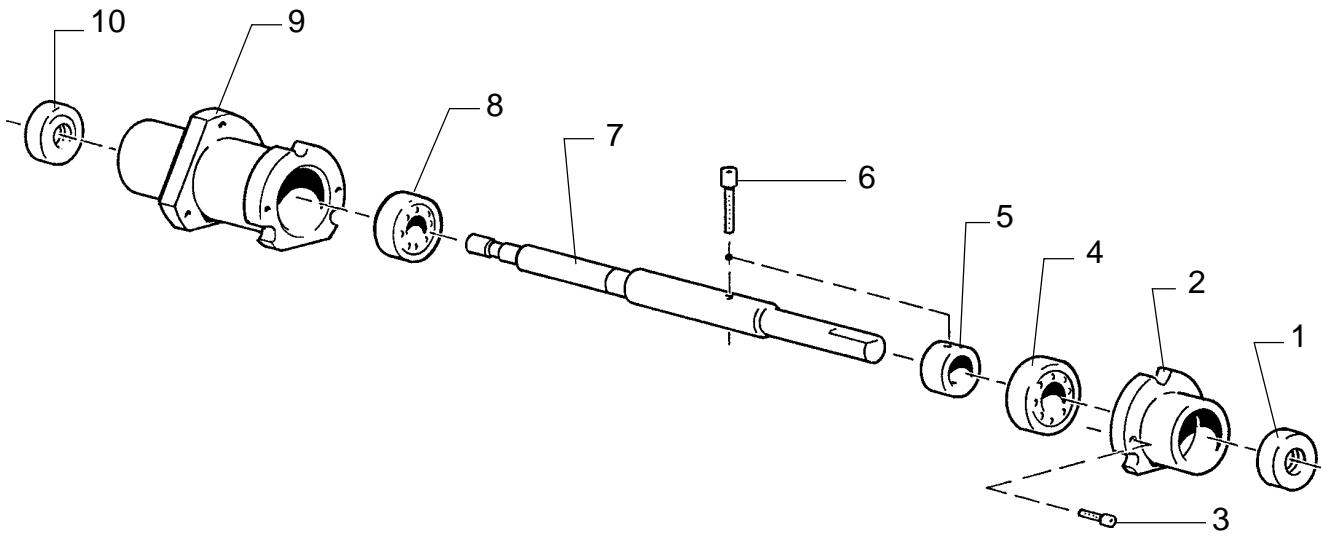

<u>Item</u>	<u>Part No.</u>	<u>Description</u>
1	21-36010	Oil Seal
2	21-98641	Cap, Bearing Housing
3	41-51557	Screw, 6-32 x 1/2"
4	21-04002	Ball Bearing
5	21-11008	Stop Collar
6	41-51210	Screw, 10-32 x 3/4"
7	21-52007	Sprocket Shaft
8	21-04021	Ball Bearing
9	21-29022	Bearing Housing
10	21-36009	Oil Seal

FIGURE 7

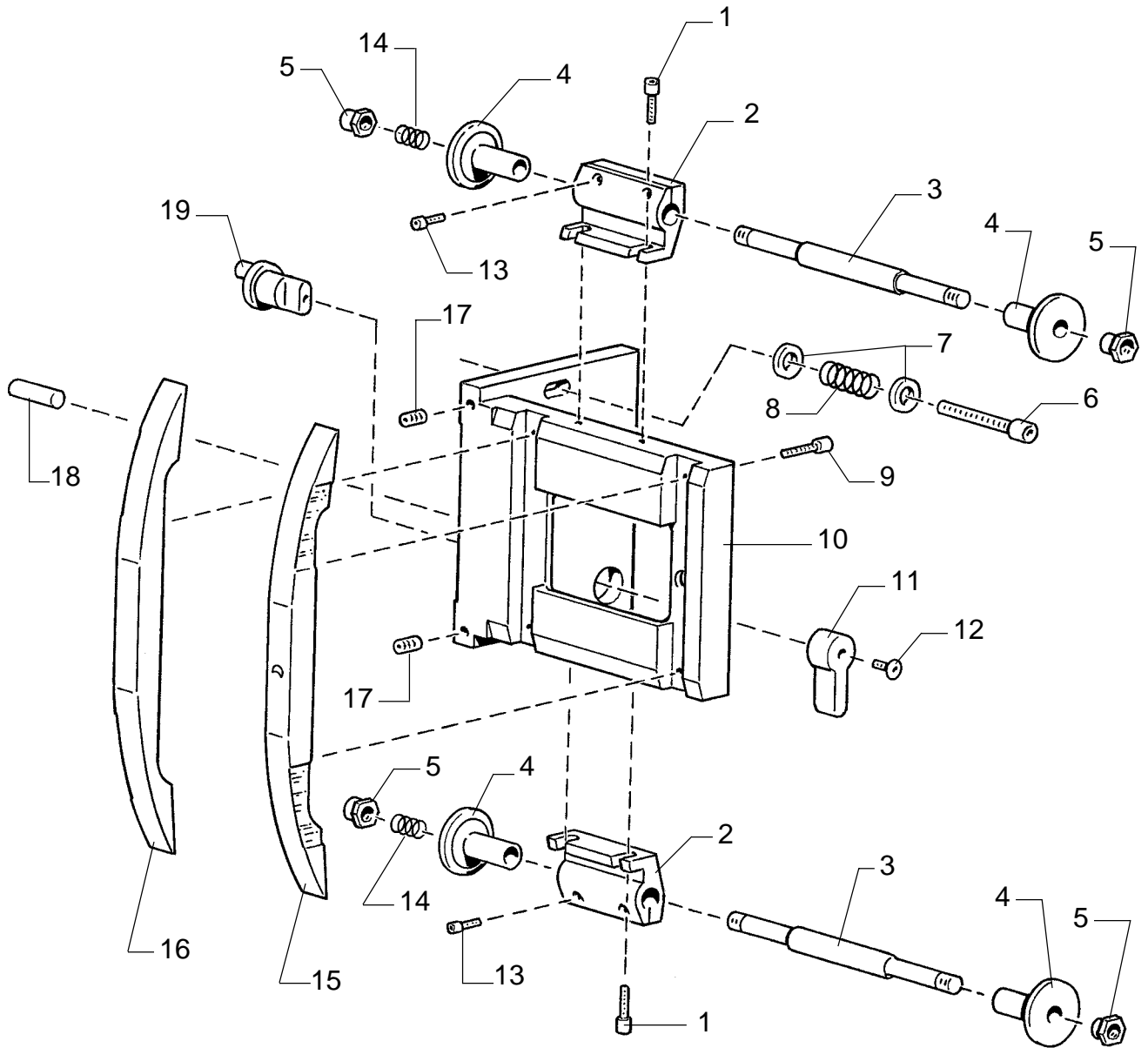

PARTS LIST

Figure 7

<u>Item</u>	<u>Part No.</u>	<u>Description</u>
1	41-51590	Screw, 6-32 x 3/8"
2	21-98659	Clamp Bracket, Guide Roller Shaft
3	21-52031	Lateral Guide Roller Shaft
4	81-49006	Lateral Guide Roller
5	82-00053	Locknut
6	41-51213	Screw, 10-32 x 1"
7	41-70050	Flatwasher, #10
8	21-58040	Compression Spring
9	41-51389	Screw, 4-40 x 1/2"
10	21-06004	Film Gate Bracket
11	21-28006	Gate Lever
12	41-51371	Screw, 8-32 x 1/2" Button Head
13	41-51391	Screw, 4-40 x 3/8" Button Head
14	81-58019	Compression Spring
15	21-98675	Gate Runner, Right (Outboard)
16	21-98639	Gate Runner, Left (Inboard)
17	41-51188	Set Screw, 1/4-20 x 5/8"
18	11-37005	Dowel Pin (staked into Main Frame)
19	21-37041	Cam, Gate Lever

FEED SPROCKET DETENT ASSEMBLY

22-60702 Opens Clockwise

22-60701 Opens Counterclockwise

INTERMITTENT SPROCKET DETENT ASSEMBLY

22-60704 Opens Clockwise

22-60703 Opens Counterclockwise

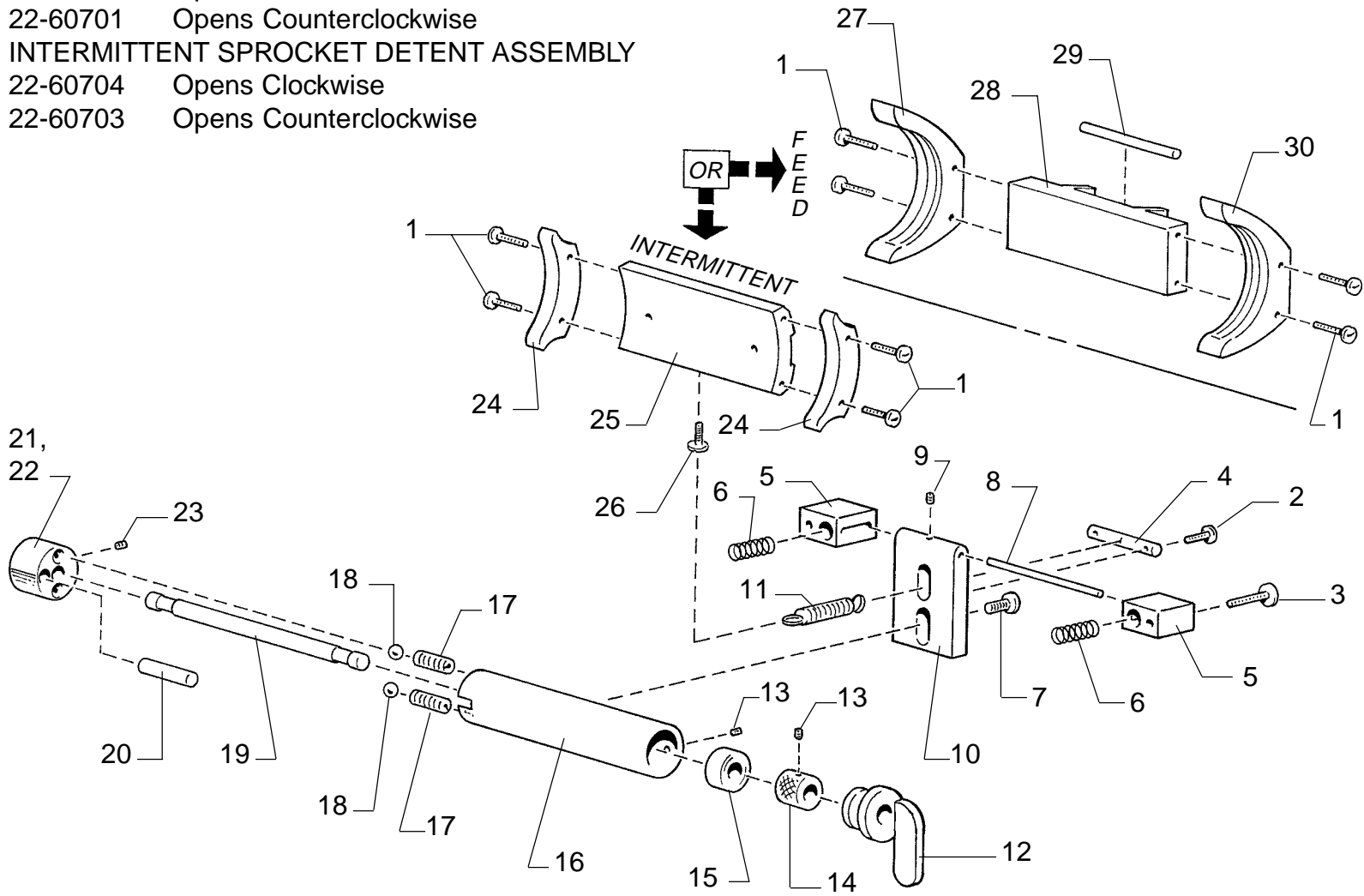

29

FIGURE 8

PARTS LIST

Figure 8

<u>Item</u>	<u>Part No.</u>	<u>Description</u>
1	41-51021	Screw, 4-40 x 1/2" Bind Head
2	41-51007	Screw, 2-56 x 3/8" Bind Head
3	41-51195	Screw, 4-40 x 5/8" Socket Head
4	22-21610	Spring Tension Shaft
5	22-20307	Spring Block
6	21-58036	Compression Spring
7	21-21834	Screw, 10-32 x 7/16" Button Head
8	22-21612	Pivot Shaft
9	41-51373	Set Screw, 4-40 x 1/8"
10	22-20308	Shoe Holder Arm
11	21-58011	Expansion Spring
12	22-40427	Detent Lever
13	41-51170	Set Screw, 8-32 x 1/8"
14	22-00008	Knurled Knob
15	21-04003	Ball Bearing
16	22-20324	Detent Arm
17	31-58001	Compression Spring
18	31-04001	Steel Ball, 3/16"
19	22-20125	Detent Shaft
20	21-37003	Dowel Pin, 3/16" x 7/8"
21	21-98292	Detent (Clockwise)
22	21-98293	Detent (Counterclockwise)
23	41-51178	Set Screw, 10-32 x 1/4"
24	22-21652	Intermittent Sprocket Shoe
25	22-20310	Intermittent Sprocket Shoe Spacer Plate
26	41-51016	Screw, 4-40 x 1/4" Bind Head
27	21-98672	Feed Sprocket Shoe, Left (Inboard)
28	21-98646	Feed Sprocket Shoe Spacer Plate
29	21-37023	Pivot Shaft
30	21-98640	Feed Sprocket Shoe, Right (Outboard)

FIGURE 9

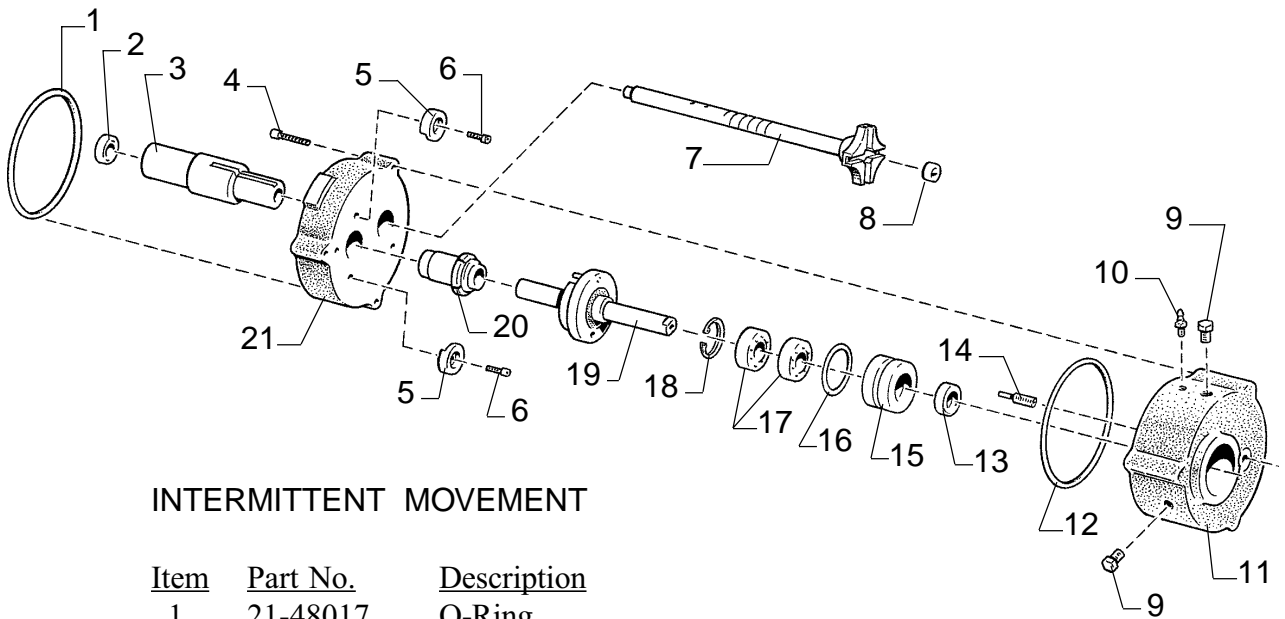

INTERMITTENT MOVEMENT

Item	Part No.	Description
1	21-48017	O-Ring
2	21-36016	Oil Seal
3	21-52009	Starwheel Shaft Bushing (with Item 7)
4	41-51214	Screw, 10-32 x 1-1/4" Socket Head (3 req'd.)
5	22-20122	Bushing Retaining Washer
6	41-51210	Screw, 10-32 x 3/4" Socket Head
7	21-52009	Starwheel Shaft & Bushing (with Item 3)
8	21-07029	Starwheel Bearing & Bushing
9	21-40249	Plug Screw, Brass
10	21-98023	Hose Barb, Oil Line
11	22-21795	Intermittent Housing, Upper Movement
11	22-21796	Intermittent Housing, Lower Movement
12	21-48017	O-Ring
13	21-36008	Oil Seal
14	21-37025	Threaded Stop Pin, Starwheel
-	41-35023	Locknut, Stop Pin (not shown)
15	22-20239	Bushing, Intermittent Housing
16	21-48004	O-Ring
17	21-04021	Ball Bearing
18	21-48023	Snap Ring, Beveled
19	21-52035	Camshaft & Bushing (with Item 20)
20	21-52035	Camshaft Bushing (with Item 19)
21	22-21778	Intermittent Base Plate Casting

