

Strong X-90 CONSOLE

“Project a STRONG Image”

F E A T U R E S

- Sturdy 14 gauge cold rolled steel construction
- Adaptable to all major projector and sound-head combinations; projects 35mm and 70mm
- Porthole centerline height is 48 inches (122cm) at 0° projection angle
- Prewired circuit breakers for xenon power supply, projector motor, sound and automation, plus 15 ampere grounded convenience outlet
- Meets SMPTE standards for screen brightness with minimum 80% uniformity
- Precision electroformed deep ellipse nickel reflector is “cold” coated; heat filters not required for normal operation
- Easy access to bulb positioning controls
- Magnetic arc stabilization standard
- Built-in blowers with directed airflow provide enhanced cooling of bulb and reflector
- Elapsed hour meter, DC ammeter and voltmeter on control panel
- Automated or Manual bulb ignition
- Safety interlock switches at all operator access doors
- Hinged lamphouse access door with arc viewing port



Designed for smaller screens, the X-90 features the eleven-inch “cold” reflector field-proven over the years in the Super Lume-X. The X-90 incorporates horizontal bulbs ranging from 700 through 2500 watts. Although smaller than the Highlight II, the X-90 provides 36 inches of standard rack space. Key locks limit access to authorized personnel only. All branch circuits are fed from a common three phase input. A MASTER contactor energizes all branch circuits simultaneously.



a division of Ballantyne of Omaha, Inc.

Strong International
Tel 402/453-4444

4350 McKinley Street
Fax 402/453-7238

Omaha NE 68112
www.strong-cinema.com

Strong X-90 CONSOLE

The X-90 console includes the Strong solid state, switching type Xenon Power Supply. This compact unit pampers your bulb with battery-smooth DC output and low inrush current (not exceeding 180%). Ripple does not exceed 3% peak-to-peak, and power efficiency averages 88%. A current adjustment potentiometer is located on the X-90 control panel adjacent to the ammeter.

EURO version available, and features dual 220 V.AC single phase inputs.

X-90 Bulbs	
Wattage	Screen Width (Max.)
700	22' (6.7 m)
1000	25' (7.6 m)
1600	30' (9.1 m)
2000	35' (10.6 m)
2500	45' (13.7 m)

Chart based upon 1.5 gain matte white screen, f2.0 lens, a CinemaScope aperture, and using a new xenon bulb.

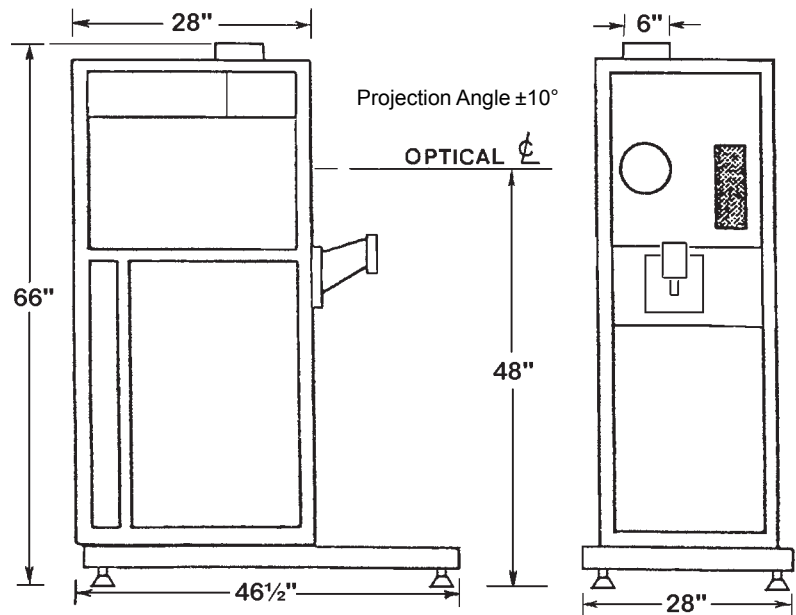

Shipping Weight: 625 lb.

with Ballantyne 35mm Projector & Soundhead: ADD 170 lb.
 with Simplex 35mm Projector & Soundhead: ADD 110 lb.
 with Century 35mm Projector & Soundhead: ADD 110 lb.
 with 35/70mm Projector & Soundheads: ADD 210 lb.
 with Sound Rack Options: ADD 150 lb. (average)

Prewire and Assembly Options

Your console can be shipped to the installation site *complete* with all desired support equipment mounted and wired. Components include:

- Projector & Soundhead
- Picture Changeover
- Reel or Guidance Arms
- Autoturret Controller
- Failsafe & Sensor Switches
- Automation Controller
- Amplifiers

- Stereo Processor
- Sound Monitor
- Non-Sync Sound Source
- Digital Sound System
- Exciter or L.E.D. Power Supply
- Remote Frame/Focus
- Auxiliary Exhaust

Components purchased from suppliers other than Strong International must be shipped to Strong's Omaha manufacturing facility with sufficient lead time.